

Hall Ticket Number:

--	--	--	--	--	--	--	--	--	--	--	--	--	--	--	--	--	--	--	--

Code No. : 12022 AS N/O (A)

VASAVI COLLEGE OF ENGINEERING (AUTONOMOUS), HYDERABAD
B.E. (CBCS) II-Semester Advanced Supplementary Examinations, July-2019

Engineering Drawing-II
(CSE, ECE & IT)

Time: 3 hours

Max. Marks: 60

Note: Answer ALL questions in Part-A and any FIVE from Part-B

Part-A (10 × 2 = 20 Marks)

1. Illustrate with sketches the position of the section plane with reference to xy line:
 - i) Section plane parallel to the VP.
 - ii) Section plane perpendicular to HP and inclined to VP.
2. What will be the position of the cube and cutting plane to get the true shape of section as rhombus? Show it with the help of a sketch.
3. List out the industrial applications of the development of surfaces.
4. State the solids whose surfaces are developed by using Radial line method.
5. What are critical points while drawing Intersection of surfaces?
6. State the situation when the line of intersection will be a curve.
7. What is the necessity for drawing isometric view?
8. Draw the Isometric scale of 6 cm and show a dimension of 4.6 cm on it.
9. What is the necessity of drawing orthographic views?
10. Show the relative positions of FV, TV, LSV and RSV in first angle projection method, assuming a rectangular plate of dimensions L x B x H.

Part-B (5 × 8 = 40 Marks)

11. A cone, base 50 mm diameter and axis 65 mm long, has its base in the HP. It is cut by a section plane perpendicular to VP and inclined to HP so that the true shape of the section is a parabola with base 40 mm. Draw the FV, sectional TV. Also draw the true shape of the section [8]
12. a) Draw the lateral surface development of a pentagonal prism of 30mm side of base and axis 70mm long is resting on one of its base on HP. [2]
b) A vertical chimney of circular section of 400mm diameter is located on the rooftop sloping at 35° to the horizontal. If the shortest portion of the chimney is 300mm high, then determine the shape of the sheet metal area from which chimney can be made. Take scale: 1: 10. [6]
13. A horizontal square prism of side 30 mm penetrates into a vertical square prism of side 40 mm. the base edges of both prism are equally inclined to VP. The axes of the prisms intersect at right angles and coinciding. Draw the lines of intersection when the axis of the horizontal prism is parallel to the both HP and VP. [8]
14. a) Draw the isometric projection of a square prism side 15mm and axis 25mm resting on one of its lateral faces on HP. [2]
b) A frustum of conical solid of base diameter 60mm and top diameter 40mm and height 35mm, when resting on its base on HP. A sphere of diameter 25mm is centrally placed over the frustum. Draw isometric view of the combination. [6]

15. a) Draw front view and top view of the figure :1 [2]
 b) Draw front view, top view and right side view of the figure :2 [6]

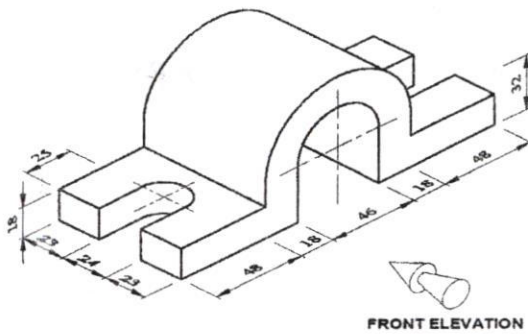

Figure: 1.

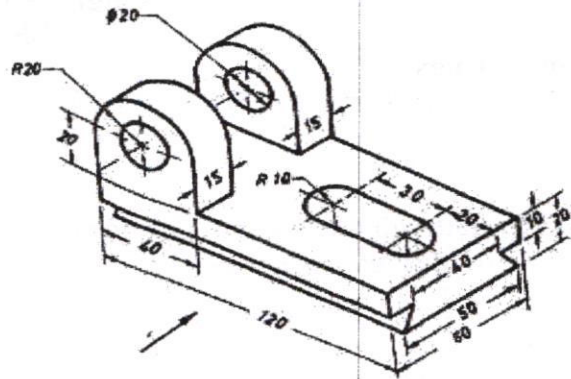

Figure: 2.

16. a) A tetrahedron of sides 50mm is resting on one of its faces with an edge of the face perpendicular to VP. it is cut by a section plane perpendicular to VP and inclined to HP such that true shape of the section is a square of side 25mm. Draw the front view, sectional top view and true shape of the section. [4]
 b) Draw the development of a cube of side 40mm with a circular hole of diameter 25mm on one of its faces. [4]
17. Answer any *two* of the following:
- a) A cylinder of base diameter 70mm and axis 100mm long is standing on its base on HP. It is completely penetrated by a horizontal cylinder of 70mm diameter and axis 120mm long, such that their axes are at right angles. Draw the curves of intersection of solids. [4]
 b) A square pyramid of side 20mm, 50mm axis is resting on a cube of side 40mm. Draw isometric view of the combination of the solids. [4]
 c) Draw front view, top view and right side view of the figure : 3 [4]

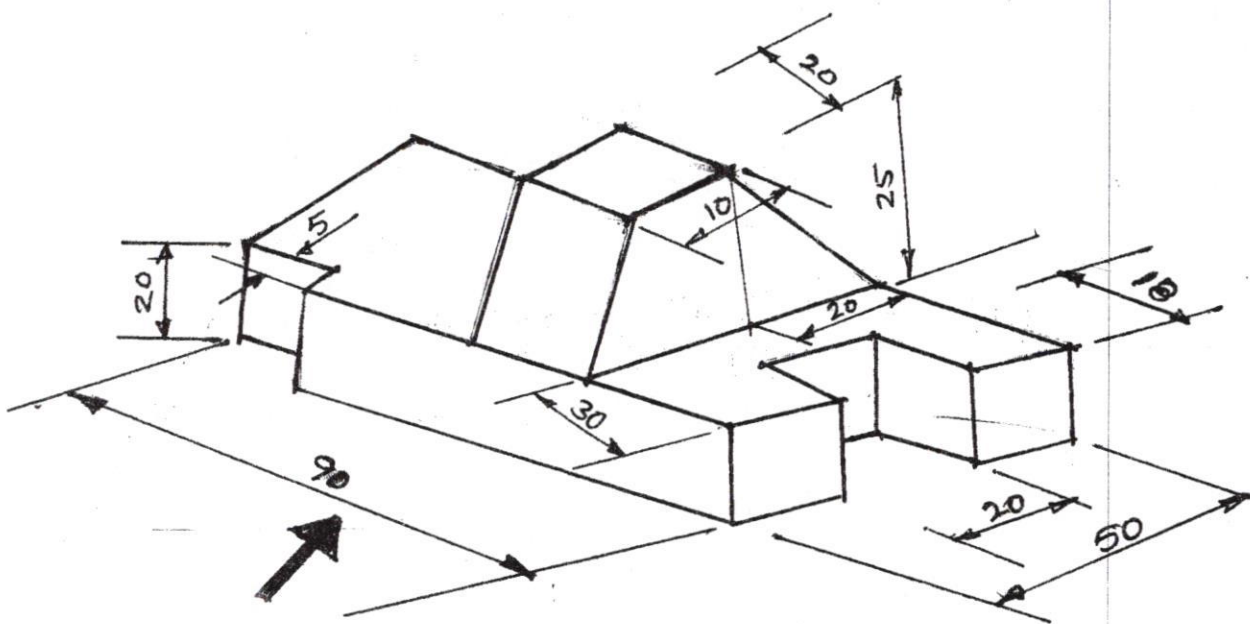

Fig: 3